



40 Gal.



60 Gal.

Reliability....

Superior design and construction, combined with innovative features, makes this container stand alone in the market place.

Durability.....

Manufactured in lightweight durable polyethylene to meet or exceed your (and our) stringent quality and performance requirements.

Service....

29 years of technical and field experience assures you that we will be there year after year to service your refuse needs. Almost three decades of experience have contributed to the design and manufacturing of containers that reduce operating cost, benefiting both the user and the collector.



90/95 Gal.

Rotonics
Major
Manufacturer
of
40 to 450 Gallon
Refuse Containers



 www.rotomics.com



200 Gal.

450 Gal.

300 Gal.



60/90 Royal Series



200 Gal. New Split Lid (6 lbs.)



We give you more container than any other manufacturer.
 Now it's time for you to decide.
The Best Just Got Better!

www.rotomics.com

Innovations:

- Front hatch is easily replaced with other colors to designate refuse, recycling or green waste collection, eliminating excessive container inventory in specific colors.
- Hatch attachment has four "MOLDED-IN" hinge holes designed to add strength to container and minimize damage to hinge area.
- In frost environments, or if gripper is not adjusted properly, four "MOLDED-IN" arm stops help prevent containers from slipping out during dumping cycle.
- Hatch rotates 110° for easier loading, dumping, and independent closing after container is emptied.

Solutions:

- Easily accessible loading height with lightweight 16 lb. front hatch door opening 70% of container.
- Domed top and sloping overlapped edges help prevent moisture from entering the container and keeps odors inside.
- Bilingual, molded-in, use instructions. (English/Spanish)
- New Split Lid (6 lbs.) for ease in loading. Easily accommodates large bags.

Quality:

- Re-designed edge at top of container improves strength.
- Area between front hatch and attachment has 16 points of contact to ensure and improve performance and longevity.
- Four large hinge pins manufactured from high-performance material minimize maintenance and reduce damage encountered with PVC.

Service:

- Retrofit: Lid and hatch fits multiple manufacturer's containers.
- Molded in nesting stops ensure ease of unloading from stacks.
- Lightweight design contributes to lighter load weight.

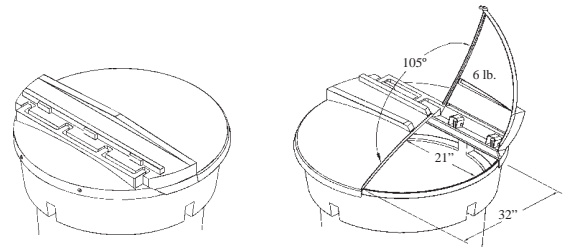

Fits most automated equipment.

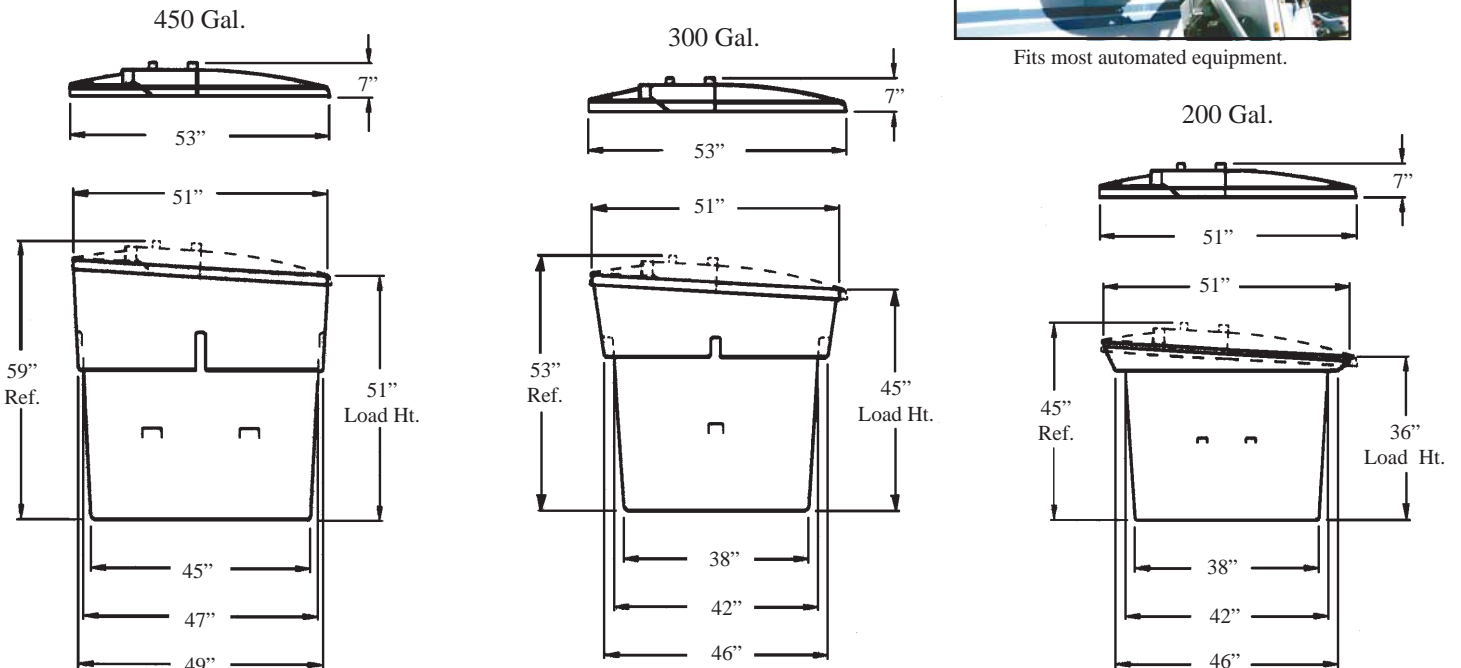

Rotonics Manufacturing Inc.

Quality Products & Exceptional Service

Be Sure To Compare...



Large Container Features:

www.rotonics.com



Re-designed edge at top of container improves strength.

Molded in nesting stops ensure ease of unloading from stacks.



New Split Lid (6 lbs.) for ease in loading. Easily accommodates large bags.



Four "MOLDED-IN" hinge holes designed to add strength to container and minimize damage to hinge area.

Area between front hatch and attachment has 16 points of contact to ensure and improve performance and longevity.



We are RMI.

Domed top and sloping overlapped edges help prevent moisture from entering the container and keeps odors inside.

Easily accessible loading height with lightweight 16 lb. front hatch door opening 70% of container.

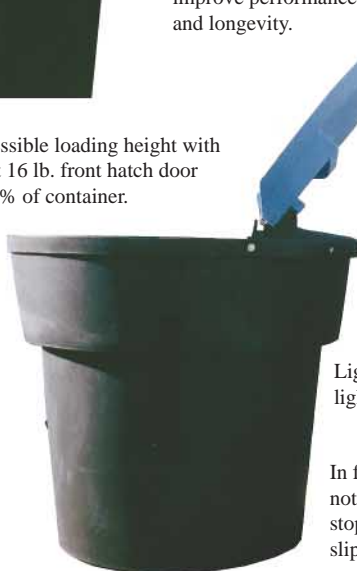

Hatch rotates 110° for easier loading, dumping, and independent closing after container is emptied.

Front hatch is easily replaced with other colors to designate refuse, recycling, or green waste collection, eliminating excessive container inventory in specific colors.

Lightweight design contributes to lighter load weight.

In frost environments, or if gripper is not adjusted properly, 4 Molded in arm stops help prevent containers from slipping out during dumping cycle.

Full lid and hatch retrofits multiple manufacturer's containers.



Four large hinge pins manufactured from high-performance material minimize maintenance and reduce damage encountered with PVC.



RMI-B
 2807 Stephen F. Austin Drive
 Brownwood, TX 76801
 Phone: 915-646-1566
 Fax: 915-643-4644
 E-mail: brownwood@rotonics.com

RMI-C
 736 Birginal Drive
 Bensenville, IL 60106
 Phone: 630-773-9510
 Fax: 630-773-4274
 E-mail: chicago@rotonics.com

RMI-D
 6770 Brighton Boulevard
 Commerce City, CO 80022
 Phone: 303-227-9300
 Fax: 303-227-9308
 E-mail: denver@rotonics.com

RMI-F
 230 Bartow Mun. Airport
 Bartow, FL 33830
 Phone: 863-534-1766
 Fax: 863-533-0407
 E-mail: florida@rotonics.com

RMI-G
 17038 South Figueroa Street
 Gardena, CA 90248
 Phone: 310-327-5401
 Fax: 310-323-9567
 E-mail: gardena@rotonics.com

RMI-I
 716 No. 11th Avenue
 Caldwell, ID 83605
 Phone: 208-454-9271
 Fax: 208-454-3089
 E-mail: idaho@rotonics.com



www.rotonics.com

Semi-Auto Carts

40 Gal.

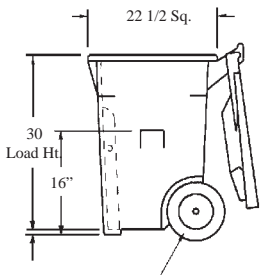

10" Wheel

60 Gal.

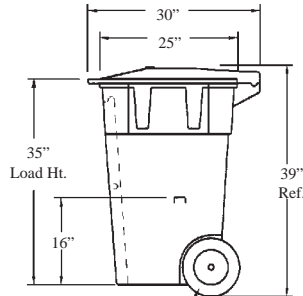

10" Wheel

95 Gal.

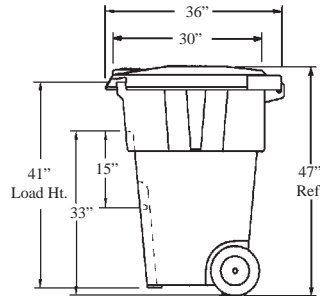

10" Wheel



Auto Carts

40 Gal.

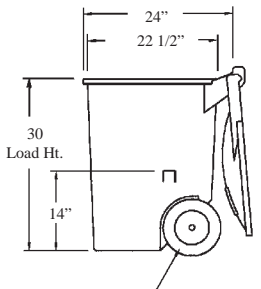

10" Wheel

60 Gal.

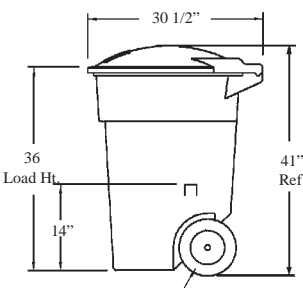

10" Wheel

90 Gal.

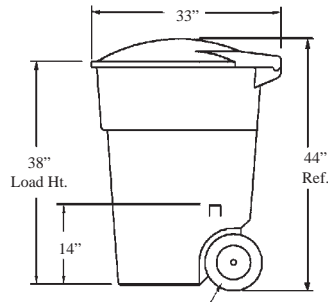

10" Wheel



Royal 60 Series

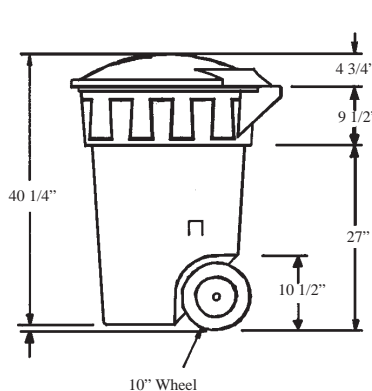

10" Wheel

Royal 90 Series

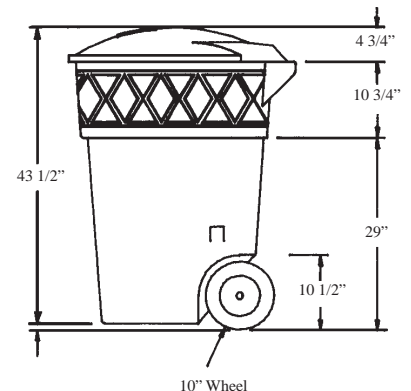

10" Wheel

Note: Royal Series Lid opens to 110°